



US Department of Transportation
Federal Aviation Administration

MAJOR REPAIR AND ALTERATION (Airframe, Powerplant, Propeller, or Appliance)

Form Approved OMB No. 2120-0020 11/30/2007 Electronic Tracking Number

For FAA Use Only

INSTRUCTIONS: Print or type all entries. See Title 14 CFR §43.9, Part 43 Appendix B, and AC 43.9-1 (or subsequent revision thereof) for instructions and disposition of this form. This report is required by law (49 U.S.C. §44701). Failure to report can result in a civil penalty for each such violation. (49 U.S.C. §46301(a))

1. Aircraft	Nationality and Registration Mark N11MH	Serial No. 24-0157	
	Make Mooney	Model M20J	Series
2. Owner	Name (As shown on registration certificate) Scott Sellmeyer		Address (As shown on registration certificate) Address 2422 S. Gatewood St
			City Wichita State KS
			Zip 67210 Country USA

3. For FAA Use Only

The data identified herein complies with applicable airworthiness requirements and is approved only for the above described aircraft subject to conformity inspection by a person authorized in FAR 43.7

FEB 07 2008

Date

Approving Inspector

ACE-FSDO-07
Wichita, KS

4. Type		5. Unit Identification			
Repair	Alteration	Unit	Make	Model	Serial No.
<input type="checkbox"/>	<input checked="" type="checkbox"/>	AIRFRAME	_____	(As described in Item 1 above)	_____
<input type="checkbox"/>	<input type="checkbox"/>	POWERPLANT			
<input type="checkbox"/>	<input type="checkbox"/>	PROPELLER			
<input type="checkbox"/>	<input type="checkbox"/>	APPLIANCE	Type		
			Manufacturer		

6. Conformity Statement

A. Agency's Name and Address		B. Kind of Agency		C. Certificate No.
Name Lauren J. Rezac		<input checked="" type="checkbox"/> U. S. Certified Mechanic		[REDACTED]
Address 9910 Jamesburg St.		<input type="checkbox"/> Foreign Certified Mechanic		
City Wichita State KS		<input type="checkbox"/> Certified Repair Station		
Zip 67212 Country USA		<input type="checkbox"/> Certified Maintenance Organization		

D. I certify that the repair and/or alteration made to the unit(s) identified in item 5 above and described on the reverse or attachments hereto have been made in accordance with the requirements of Part 43 of the U.S. Federal Aviation Regulations and that the information furnished herein is true and correct to the best of my knowledge.

Extended range fuel per 14 CFR Part 43 App. B <input type="checkbox"/>	Signature/Date of Authorized Individual 2-07-08
--	---

7. Approval for Return to Service

Pursuant to the authority given persons specified below, the unit identified in item 5 was inspected in the manner prescribed by the Administrator of the Federal Aviation Administration and is Approved Rejected

BY	FAA Fit. Standards Inspector	Manufacturer	Maintenance Organization	Persons Approved by Canadian Department of Transport
	FAA Designee	Repair Station	<input checked="" type="checkbox"/> Inspection Authorization	Other (Specify)

Certificate or Designation No. 	Signature/Date of Authorized Individual 2-07-08
------------------------------------	---

NOTICE

Weight and balance or operating limitation changes shall be entered in the appropriate aircraft record. An alteration must be compatible with all previous alterations to assure continued conformity with the applicable airworthiness requirements.

8. Description of Work Accomplished

(If more space is required, attach additional sheets. Identify with aircraft nationality and registration mark and date work completed.)

N11NH

Nationality and Registration Mark

2-07-08

Date

Remove existing landing light from lower cowling. Install XeVision High Intensity Discharge (HID) light assembly (kit # XV-46-SL) into vacated position. The ballast was mounted on the firewall. The existing switches, wiring and circuit protection were reused. The provided HID wire harness from the ballast to the light assembly was routed directly and secured for chafe protection. All work to be performed referring to AC43.13-2A Chapter 1, AC43.13-1B Chapters 10 & 11 and XeVision Installation Instructions. Amended aircraft Weight & Balance and equipment Lists.

The following are instructions for continued airworthiness for this altered airframe.

1. INTRODUCTION: This installation was accomplished to increase landing light illumination and to increase the service life.
2. DESCRIPTION: Removed existing landing light and installed XeVision HID light.
3. CONTROL OPERATION: The light is controlled with the existing aircraft landing light switch. There are no special procedures.
4. SERVICE INFORMATION: The components are not field repairable and must be replaced with approved components.
5. MAINTENANCE INSTRUCTIONS: The lighting system is to be maintained in accordance with FAR Part 43.13. Inspection is to be performed in accordance with FAR Part 43.15.
6. TROUBLESHOOTING INFORMATION: If the circuit breaker pops, replace the ballast unit. If the light does not illuminate, remove the light or ballast, verify function and replace as required. Bench testing must be done in accordance with the XeVision installation and operation Instructions which contain warnings for bench testing.
7. REMOVAL AND REPLACEMENT INFORMATION: The HID lamp is removed and replaced in the same manner as the original lamp. The ballast is attached to the firewall using standard procedures and hardware. The wire harness between the ballast and the lamp shall be removed in accordance with XeVision installation and operation Instructions.
8. DIAGRAMS: Access is through the removal of the cowling. No diagrams are required.
9. SPECIAL INSPECTION REQUIREMENTS: N/A
10. APPLICATION OF PROTECTIVE TREATMENTS: N/A
11. SPECIAL HARDWARE: N/A
12. SPECIAL TOOLS: N/A
13. COMMUTER CATEGORY AIRCRAFT: N/A

Additional Sheets Are Attached

12 VDC Wiring Diagram

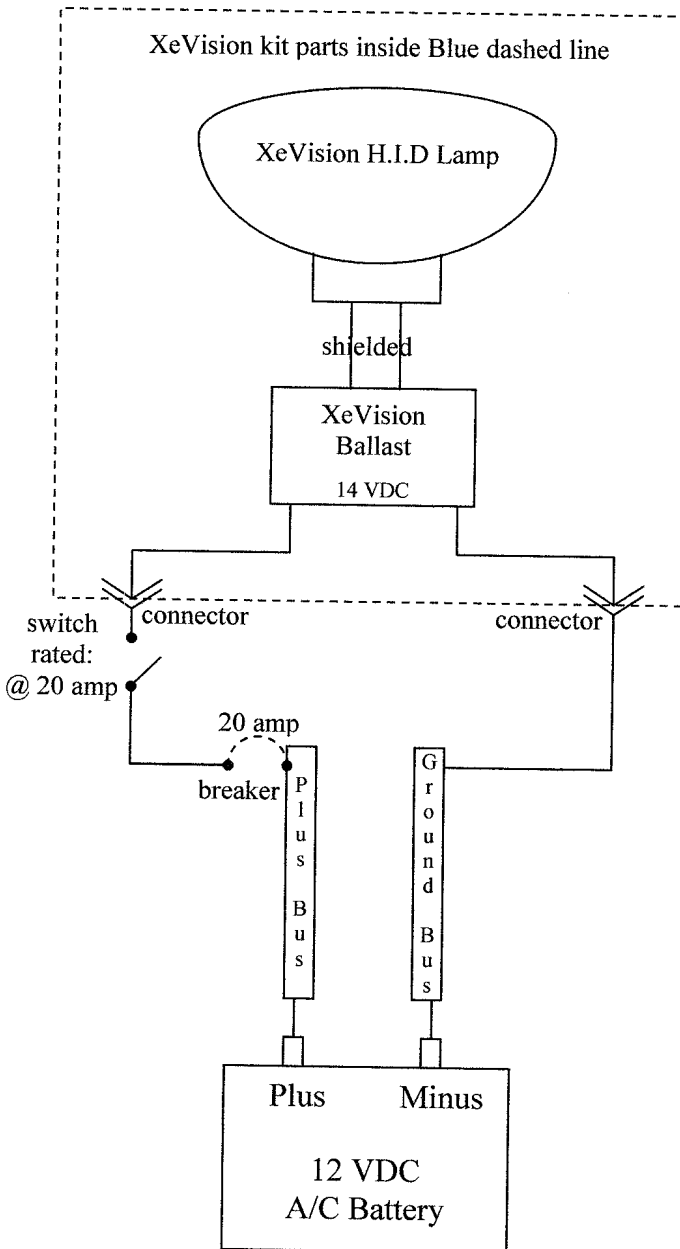

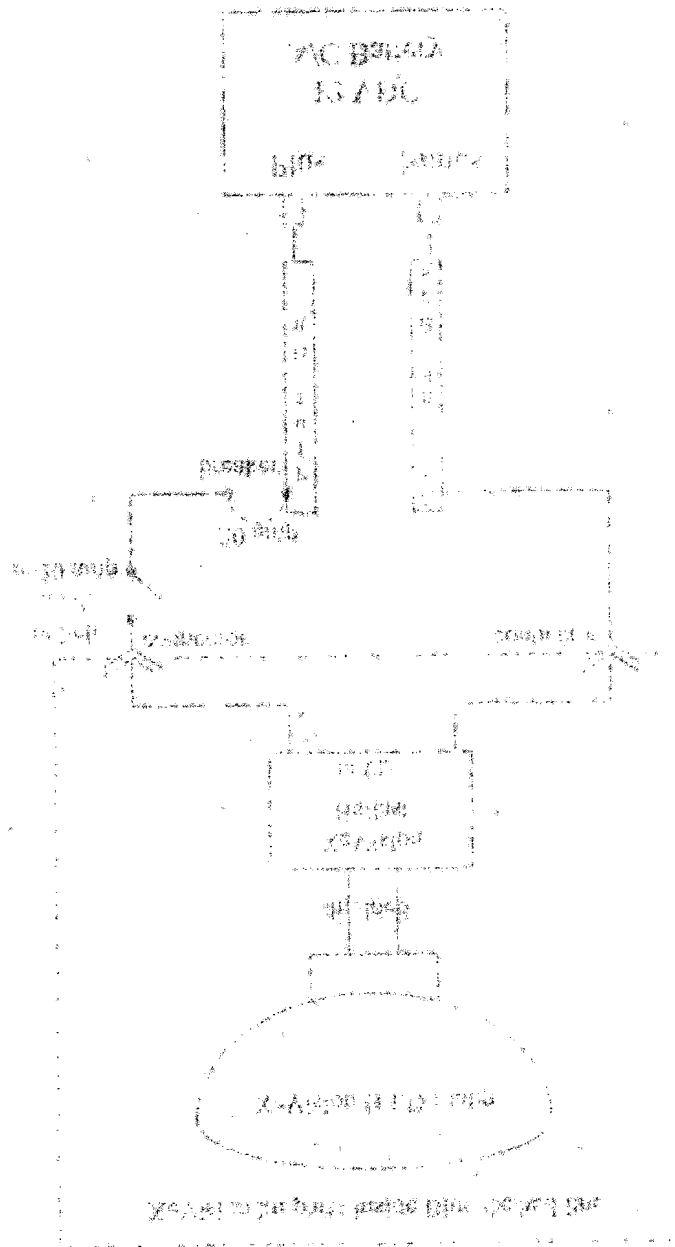

Diagram of the power distribution system.

AC BOLA 13750